



cincinnati time systems

Model 2000 Remote Installation Instructions (9600 Baud Modem)

Description

Figure 1 shows how all of the system components are connected on Remote Terminal setup.
(Note: Figures are not to scale).

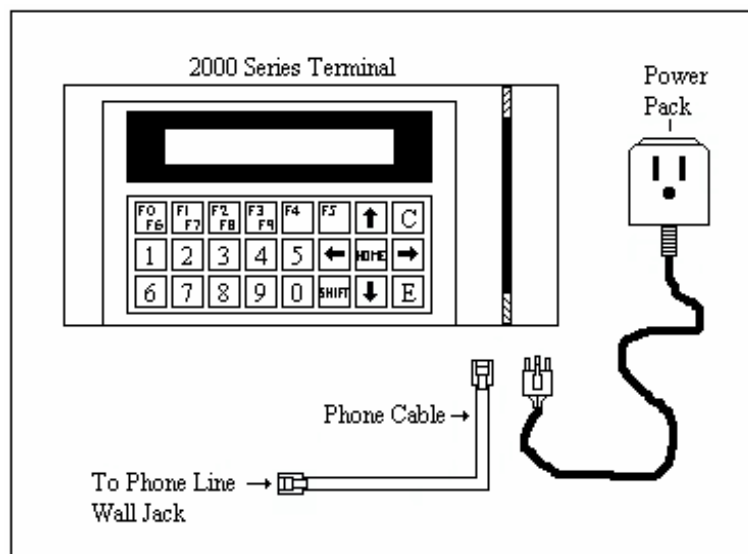

Figure 1

Installing the Terminal

- It is recommended to have a dedicated analog phone line installed prior to the installation of the Remote Terminal.
- As you install the system, refer to Figure 1 in addition to the other figures mentioned below.

STEP 1

Determine a mounting site for the Terminal. The Terminal's Wall Mount Base can be attached to any flat surface that is in good condition. Care should be taken to place it in a location where the Terminal will not be bumped. The base of the Terminal should be about 4 feet (48 inches) from the surface of the floor in an area where lighting will not cause glare on the Terminal's display (Figure 2). A 120 VAC outlet should be located within 5 feet of the Terminal.

STEP 2

Using the keys provided, unlock the Terminal and separate it from the Wall Mount Base. Remove any Snap Modules that are installed in the Base and put them aside for now. Locate the 4 mounting holes on the inside of the Base to mark the wall for the locations of the screws. Make sure the Wall Mount Base is level. Remove the Base from the wall and prepare the wall (if necessary); for example, drill pilot holes or tap holes. Place the Base on the wall and mount it using appropriate screws and anchors to secure it to the wall (Figure 2).

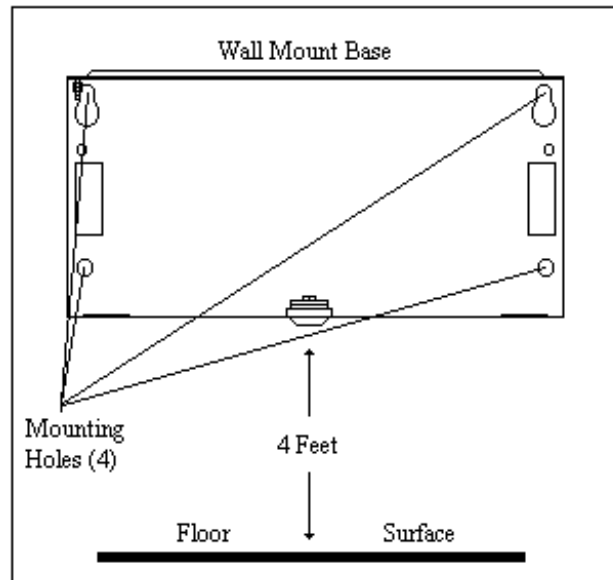

Figure 2

STEP 3

Locate a desired Cable Access knockout on the Mounting Base. Feed one end of the Phone cable, DC Plug for the power pack, and any wires for the Relay (if applicable) through a knockout. Do not make any connections inside the Terminal yet (Figure 3).

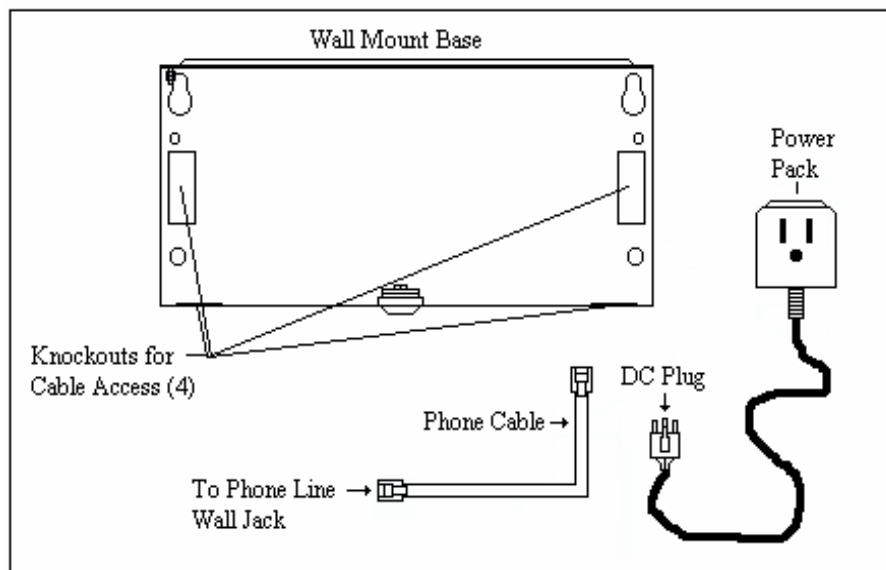

Figure 3

STEP 4

Depending on the configuration of the Terminal that was ordered, there are 1 or 2 Snap Modules to be re-installed into the Wall Mount Base. Starting from the right side of the Base, insert the Modem Snap Module. If a UPS Battery Module was ordered, then insert it to the left of the Modem Module (Figure 4).

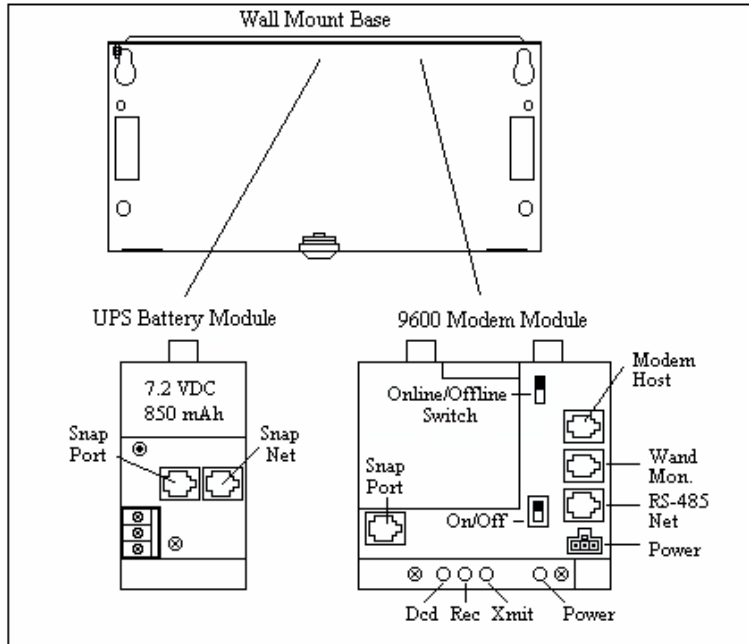

Figure 4

STEP 5

Figure 5 shows how all of the Snap Modules connect to each other and to the Terminal. Depending on the configuration of the Terminal that was ordered, follow the diagram on connecting the Modem Snap Module and optional UPS Battery Module to the Terminal. Plug one end of the phone cable into the wall jack. Plug the other end of the phone cable to the Modem Host port on the Modem Module. (If only the Modem Module was ordered, connect one end of the 8 conductor Comm / Power cable to the Snap Port on the Modem Module and the other end into the Snap Term port on the Series 2000 Terminal (Figure 5)).

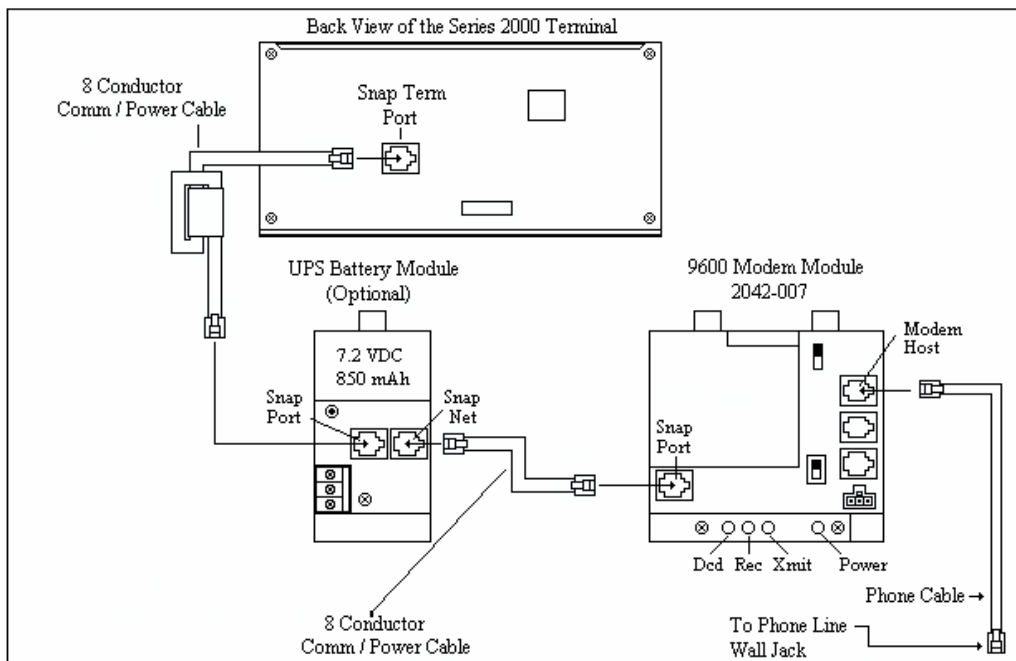

Figure 5

STEP 6

If the configuration of the Terminal includes a UPS Battery Module and the Relay is to be used, follow the Relay Connection Chart on Figure 6 on how to connect the wires to either ring bells or for door access. If the bells or door access strike needs more amperage than the Relay can handle, then call ADI Support Dept. for additional options.

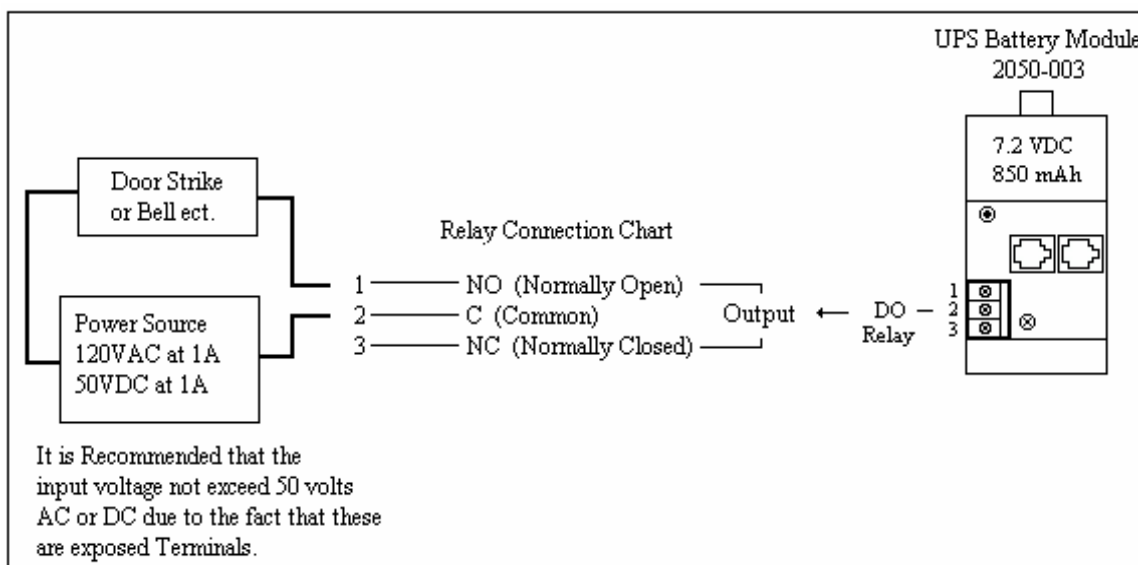

Figure 6

STEP 7

On the Modem Module, move either the Online / Offline switch to the "Offline" position or move the Use / Test switch to the "Test" position and move the On / Off switch to the "ON" position (Figure 7). Plug the DC Plug from the power pack into the Power connector on the Modem Module (Figure 7).

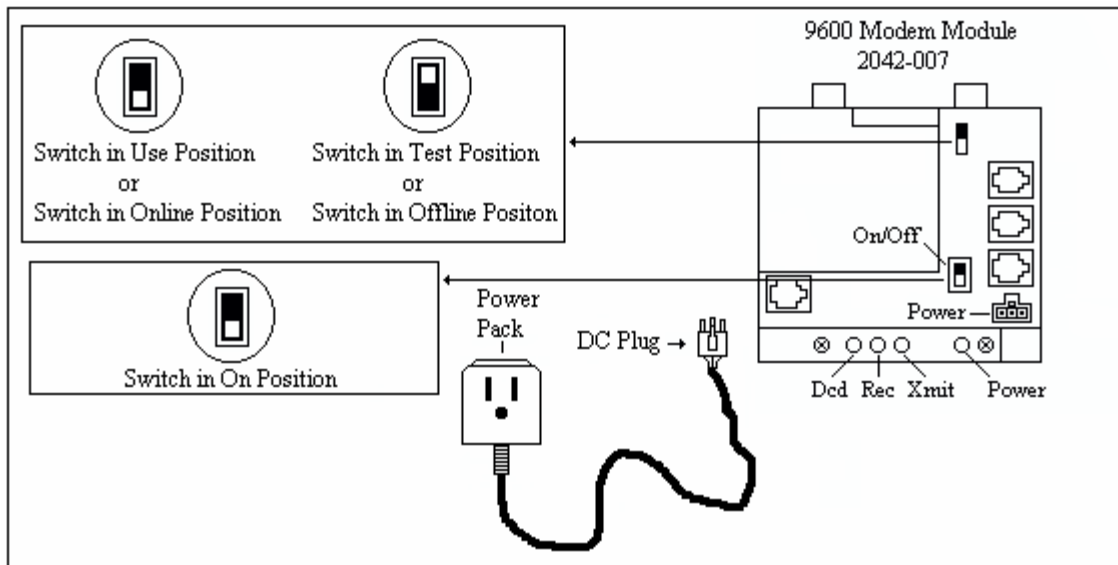

Figure 7

STEP 8

Place the Terminal over the Wall Mount Base and use the key to lock it in place.

STEP 9

Plug the Terminal's Power Pack into a 120 VAC outlet (Figure 1). The Terminal will run a series of self-tests and prompt "Setup Mode?" on the top line of the display. The bottom line of the display shows the Baud Rate, Parity, Host Delay, Terminal Address, Protocol Option, and the type of Reader (Figure 8).

```

Setup Mode?
19,O,HD0,A00,NO,BC
  
```

Figure 8

STEP 10

Press the "E" key once on the Terminal and the prompt "BAUD RATE" appears on the top line of the display (Figure 9). The bottom line of the display will have an underline under the current setting. The default Baud Rate is 19200. Set the Baud Rate to 9600. Press either the up or down arrow keys on the Terminal until it reads "96" then press the right arrow key on the Terminal.

```

BAUD RATE
19,O,HD0,A00,NO,BC
  
```

Figure 9

STEP 11

The prompt on the top line of the display should now read "PARITY" (Figure 10). The bottom line of the display will have an underline under the current setting. The default Parity setting is "ODD". If it is not "ODD", press either the up or down arrow keys on the Terminal until it reads "O" then press the right arrow key on the Terminal.

```

PARITY
96,O,HD0,A00,NO,BC
  
```

Figure 10

STEP 12

The prompt on the top line of the display should now read “HOST DELAY” (Figure 11). The bottom line of the display will have an underline under the current setting. The default Host Delay is “0”. If it is not “0”, press either the up or down arrow keys on the Terminal until it reads “0” then press the right arrow key on the Terminal.

```
HOST DELAY
96,O,HD0,A00,NO,BC
```

Figure 11

STEP 13

The prompt on the top line of the display should now read “ADDRESS” (Figure 12). The bottom line of the display will have an underline under the current setting. The default Address is “00”. Press the up arrow key on the Terminal until it reads “01”. Press the right arrow key on the Terminal.

```
ADDRESS
96,O,HD0,A01,NO,BC
```

Figure 12

STEP 14

The prompt on the top line of the display should now read “PROTOCOL OPTION” (Figure 13). The bottom line of the display will have an underline under the current setting. The default Protocol Option is “NO”. If it is not “NO”, press either the up or down arrow keys on the Terminal until it reads “NO” then press the right arrow key on the Terminal.

```
PROTOCOL OPTION
96,O,HD0,A01,NO,BC
```

Figure 13

STEP 15

The prompt on the top line of the display should now read “READER” (Figure 14). The bottom line of the display will have an underline under the current setting. If the Reader type is not correct, press the up or down arrow keys on the Terminal until it reads the correct type of Reader. (For example, Figure 14 below shows that the Reader is set to “BC” which is for a Barcode Reader. If the Terminal has a Magnetic Stripe Track II Reader, then the setting on the Terminal would be set for “M2”, for a Biometric Reader, the setting on the Terminal would be set for “BIO”, for a Proximity Reader, the setting on the Terminal would be set to “PROX”). Press the “HOME” key on the Terminal and the top line of the display will again read “Setup Mode” with the correct settings on the bottom line.

```
READER
96,O,HD0,A00,BC
```

Figure 14

STEP 16

Use the key to open up the Terminal from the Wall Mount Base. On the Modem Module, move either the Online / Offline switch back to the “Online” position or move the Use / Test switch back to the “Use” position (Figure 7). The Terminal will go through another series of self-tests, initialize the Modem, and the prompt “LOCKED, NO DOWNLOAD!” will be displayed on the top line of the display (Figure 15). Place the Terminal back over the Wall Mount Base and use the key to lock it in place.

```
LOCKED, NO DOWNLOAD!
```

Figure 15

- * This completes the Remote Installation of the Model 2000 Terminal. The rest of the Terminal programming will be done on the PC in the Time & Attendance software.