



cincinnati time systems

Model 2000 Direct Installation Instructions (RS-232/485 Module)

Description

Figure 1 shows how all of the system components are connected. (Note: Figures are not to scale).

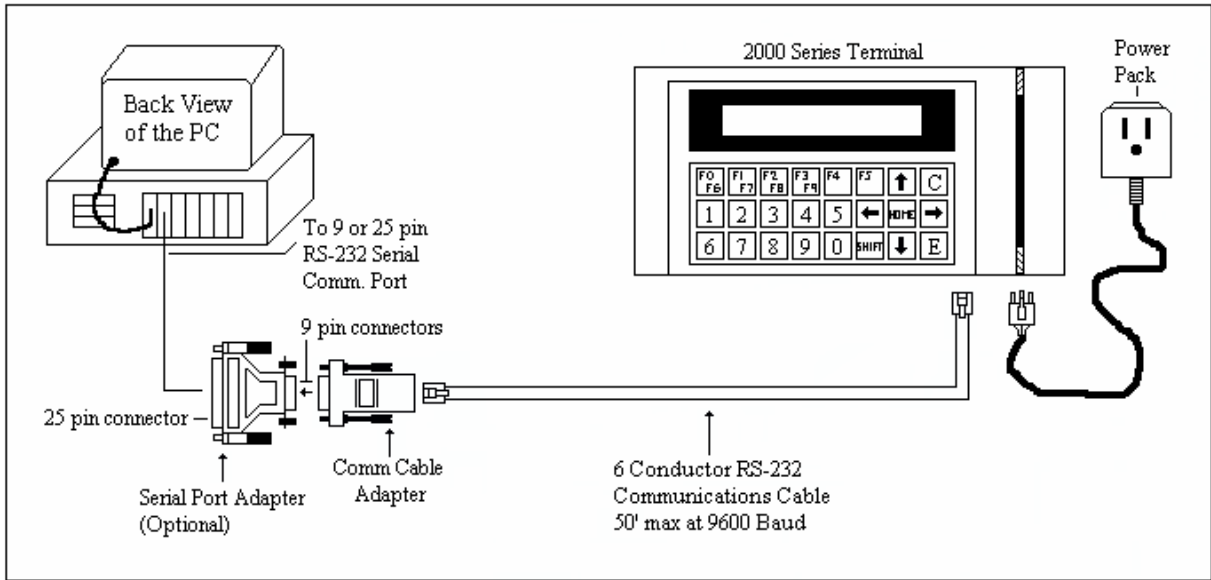

Figure 1

Installing the Terminal

- As you install the system, refer to Figure 1 in addition to the other figures mentioned below.

STEP 1

Determine a mounting site for the Terminal, and run the 6 conductor communications cable from the PC to the mounting site. Figure 2 below shows the pinout for the 6 conductor communications cable.

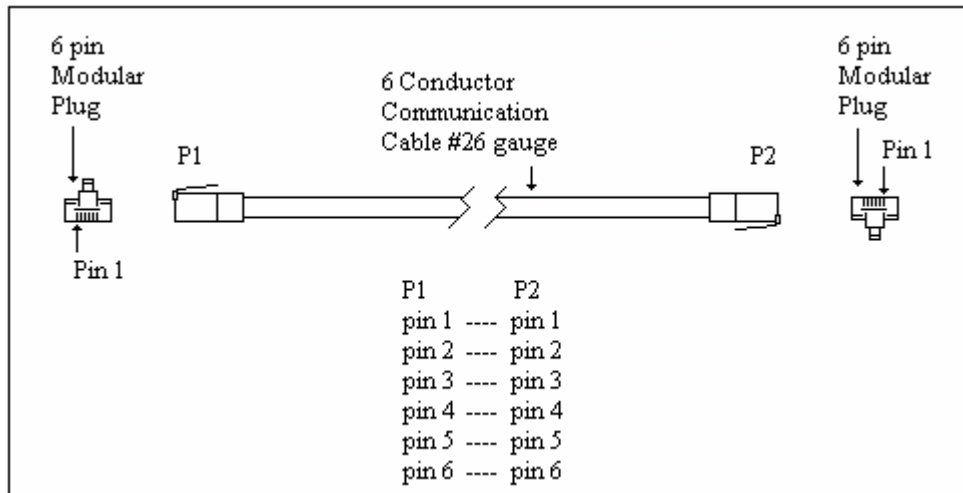

Figure 2

STEP 2

If a 9 pin serial communication port on the PC is to be used, then connect the 9 pin end of the Comm Cable Adapter into the 9 pin serial port and secure it in place (Figure 1). If a 25 pin serial port is to be used, then connect a 25 to 9 pin serial port adapter (not supplied) into the 25 pin serial port on the PC and secure it in place (Figure 1). Plug the 9 pin end of the Comm Cable Adapter into the 9 pin end of the serial port adapter and secure it in place (Figure 1).

STEP 3

Plug one end of the 6 conductor communications cable into the modular jack on the Comm Cable Adapter (Figure 3).

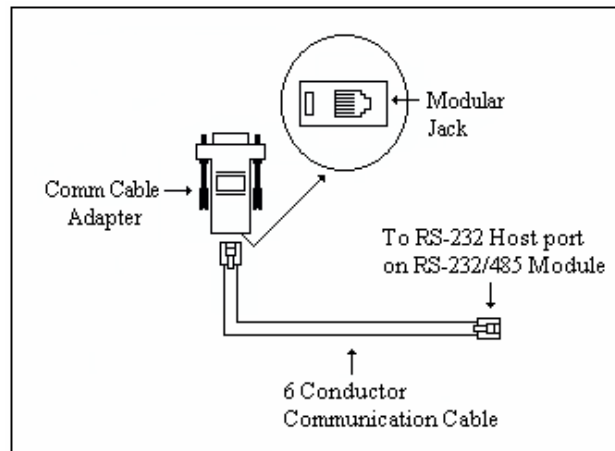

Figure 3

STEP 4

The Terminal's Wall Mount Base can be attached to any flat surface that is in good condition. Care should be taken to place it in a location where the Terminal will not be bumped. The base of the Terminal should be about 4 feet (48 inches) from the surface of the floor in an area where lighting will not cause glare on the Terminal's display (Figure 4).

STEP 5

Using the keys provided, unlock the Terminal and separate it from the Wall Mount Base. Remove any Snap Modules that are installed in the Base and put them aside for now. Locate the 4 mounting holes on the inside of the Base to mark the wall for the locations of the screws. Make sure the Wall Mount Base is level. Remove the Base from the wall and prepare the wall (if necessary); for example, drill pilot holes or tap holes. Place the Base on the wall and mount it using appropriate screws and anchors to secure it to the wall (Figure 4).

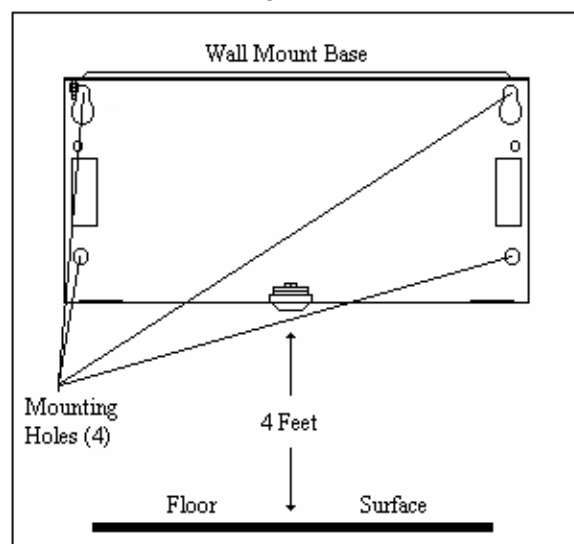

Figure 4

STEP 6

Locate a desired Cable Access knockout on the Mounting Base. Feed the other end of the 6 conductor communications cable, DC Plug for the power pack, and any wires for the Relay (if applicable) through a knockout (Figure 5).

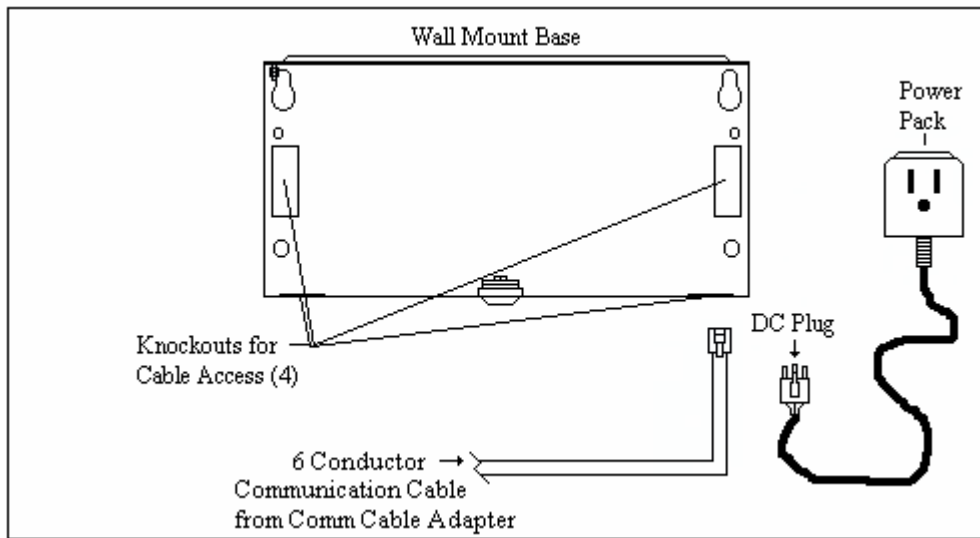

Figure 5

STEP 7

Depending on the configuration of the Terminal that was ordered, there are 1 or 2 Snap Modules to be re-installed into the Wall Mount Base. Starting from the right side of the Base, insert the RS-232/485 Snap Module. If a UPS Battery Module was ordered, then insert it to the left of the RS-232/485 Module (Figure 6).

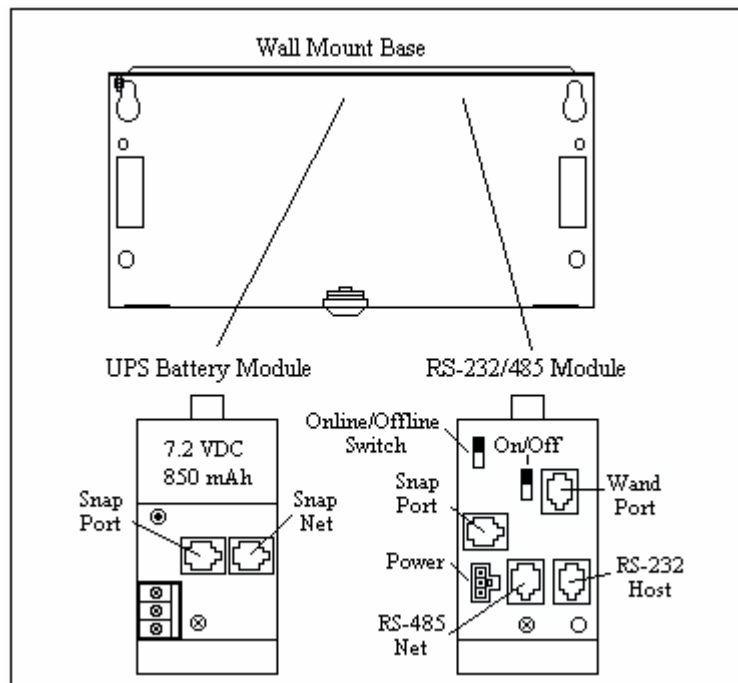

Figure 6

STEP 8

The diagram below shows how all of the Snap Modules connect to each other and to the Terminal. Depending on the configuration of the Terminal that was ordered, follow the diagram below on connecting the RS-232/485 Snap Module and optional UPS Battery Module to the Terminal. (For example, if only a RS-232/485 Snap Module was ordered, plug the 6 conductor end, to the RS-232 Host port. Then connect one end of the 8 conductor Comm / Power cable to the Snap Port on the RS-232/485 Module and the other end into the Snap Term port on the Series 2000 Terminal (Figure 7)).

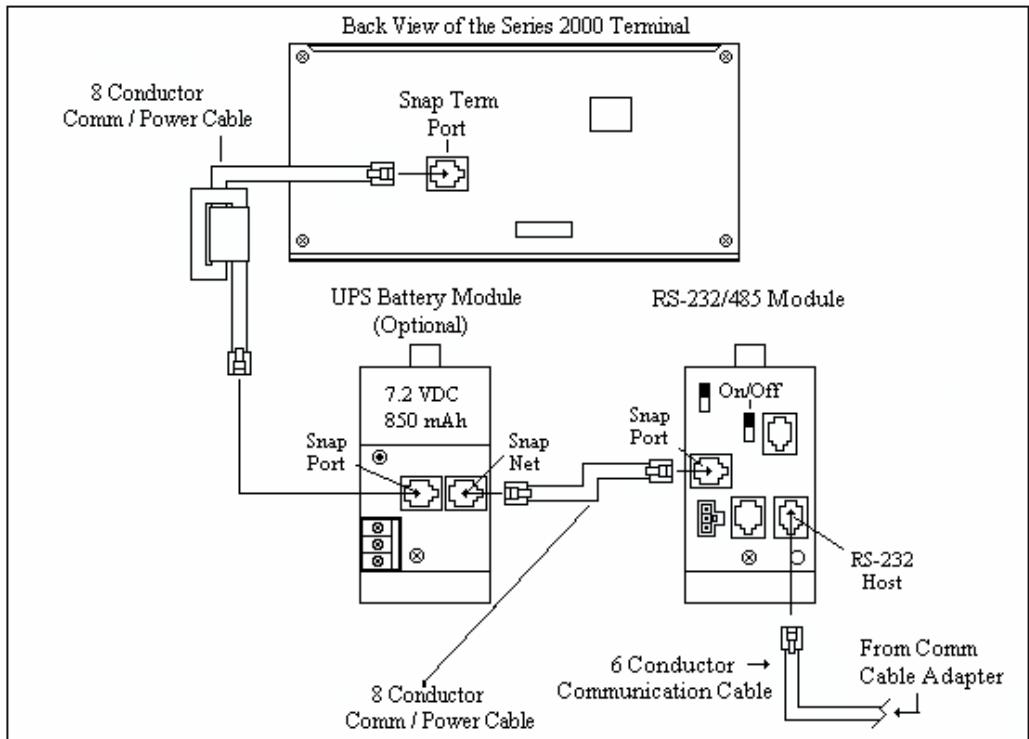

Figure 7

STEP 9

If the configuration of the Terminal includes a UPS Battery Module and the Relay is to be used, follow the Relay Connection Chart on Figure 8 on how to connect the wires to either ring bells or for door access. If the bells or door access strike needs more amperage than the Relay can handle, then call ADI Support Dept. for additional options.

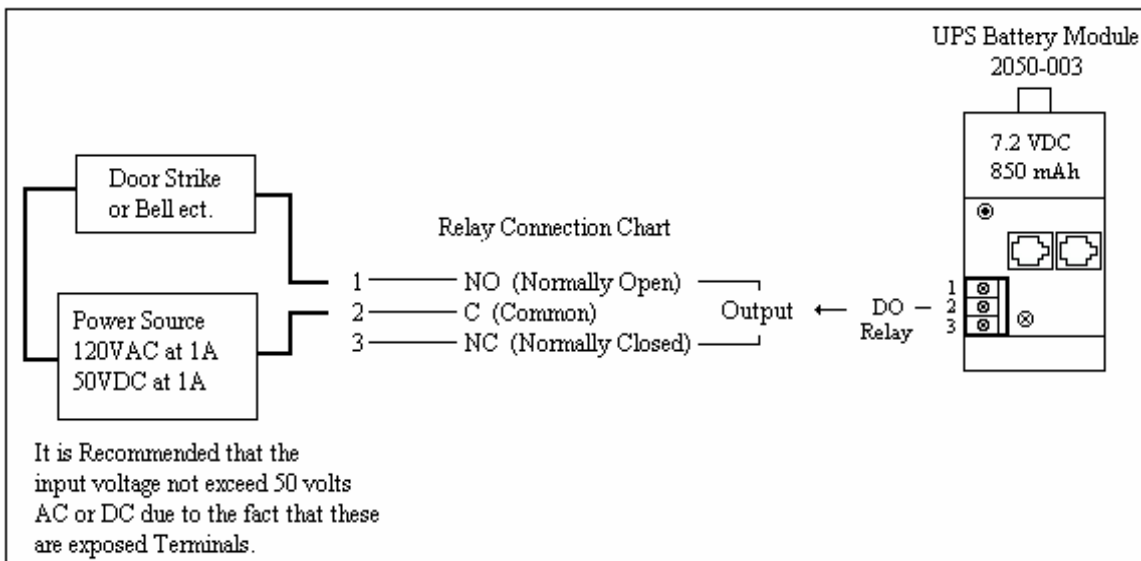

Figure 8

STEP 10

On the RS-232/485 Module, move either the Online / Offline switch to the “Offline” position or the Use / Test switch to the “Test” position and move the On / Off switch to the “ON” position (Figure 9). Plug the DC Plug from the power pack into the Power connector on the RS-232/485 Module (Figure 9).

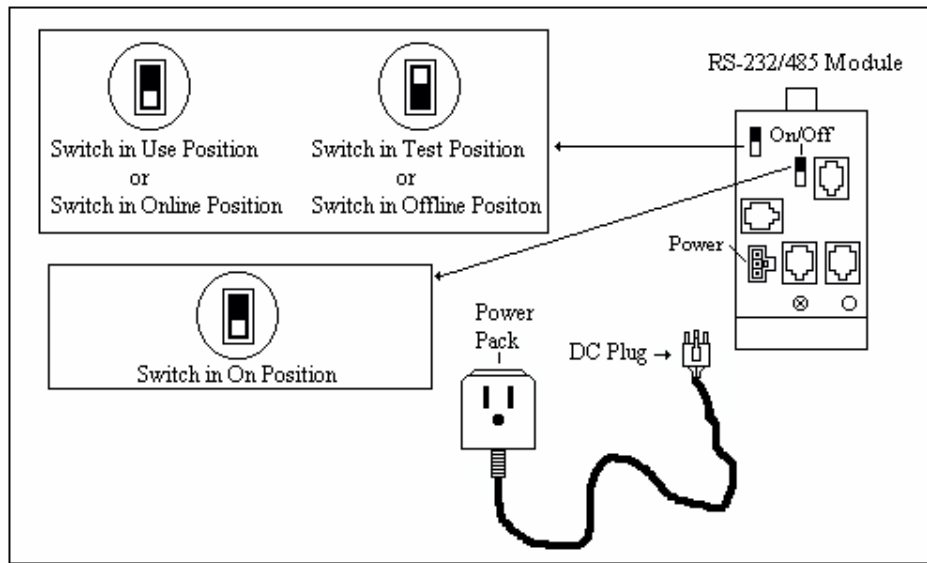

Figure 9

STEP 11

Place the Terminal over the Wall Mount Base and use the key to lock it in place.

STEP 12

Plug the Terminal’s Power Pack into a 120 VAC outlet (Figure 1). The Terminal will run a series of self-tests and prompt “Setup Mode?” on the top line of the display. The bottom line of the display shows the Baud Rate, Parity, Host Delay, Terminal Address, Protocol Option, and the type of Reader (Figure 10).

```
Setup Mode?  
19,O,H00,A00,NO,BC
```

Figure 10

STEP 13

Press the “E” key once on the Terminal and the prompt “BAUD RATE” appears on the top line of the display (Figure 11). The bottom line of the display will have an underline under the current setting. The default Baud Rate setting is 19200. Set the Baud Rate to 9600. Press either the up or down arrow keys on the Terminal until it reads “96” then press the right arrow key on the Terminal.

```
BAUD RATE  
19,O,H00,A00,NO,BC
```

Figure 11

STEP 14

The prompt on the top line of the display should now read “PARITY” (Figure 12). The bottom line of the display will have an underline under the current setting. The default Parity setting is “ODD”. If it is not “ODD”, press either the up or down arrow keys on the Terminal until it reads “O” then press the right arrow key on the Terminal.

```
PARITY  
96,O,H00,A00,NO,BC
```

Figure 12

STEP 15

The prompt on the top line of the display should now read “HOST DELAY” (Figure 13). The bottom line of the display will have an underline under the current setting. The default Host Delay is “0”. If it is not “0”, press either the up or down arrow keys on the Terminal until it reads “0” then press the right arrow key on the Terminal.

```
HOST DELAY
96,O,HD0,A00,NO,BC
```

Figure 13

STEP 16

The prompt on the top line of the display should now read “ADDRESS” (Figure 14). The bottom line of the display will have an underline under the current setting. The default Address is “00”. Press the up arrow key on the Terminal until it reads “01”. Press the right arrow key on the Terminal.

```
ADDRESS
96,O,HD0,A01,NO,BC
```

Figure 14

STEP 17

The prompt on the top line of the display should now read “PROTOCOL OPTION” (Figure 15). The bottom line of the display will have an underline under the current setting. The default Protocol Option is “NO”. If it is not “NO”, press either the up or down arrow keys on the Terminal until it reads “NO” then press the right arrow key on the Terminal.

```
PROTOCOL OPTION
96,O,HD0,A01,NO,BC
```

Figure 15

STEP 18

The prompt on the top line of the display should now read “READER” (Figure 16). The bottom line of the display will have an underline under the current setting. If the Reader type is not correct, press the up or down arrow keys on the Terminal until it reads the correct type of Reader. (For example, Figure 16 below shows that the Reader is set to “BC” which is for a Barcode Reader. If the Terminal has a Magnetic Stripe Track II Reader, then the setting on the Terminal would be set for “M2”, for a Biometric Reader, the setting on the Terminal would be set to “BIO”, for a Proximity Reader, the setting on the Terminal would be set to “PROX”). Press the “HOME” key on the Terminal and the top line of the display will again read “Setup Mode” with the correct settings on the bottom line.

```
READER
96,O,HD0,A01,NO,BC
```

Figure 16

STEP 19

Use the key to open up the Terminal from the Wall Mount Base. On the RS-232/485 Module, move either the Online / Offline switch back to the “Online” position or move the Use / Test switch back to the “Use” position (Figure 9). The Terminal will go through another series of self-tests and the prompt “LOCKED, NO DOWNLOAD!” will be displayed on the top line of the display (Figure 17). Place the Terminal back over the Wall Mount Base and use the key to lock it in place.

```
LOCKED, NO DOWNLOAD!
```

Figure 17

* This completes the RS-232 Direct Installation of the Model 2000 Terminal. The rest of the Terminal programming will be done on the PC in the Time & Attendance software.